

Recipient: All International Offices  
Pages: 5

Newsletter No. 3/2019

5. 12. 2019

Dear DEPRAG-INDUSTRIAL Associate,  
we take the opportunity to inform you about new and improved products that were either added to our product line or where we made improvements. Detailed technical information and pictures, as well as a catalog in PDF-format can be found on our website [www.deprag.cz](http://www.deprag.cz).

## Novinky:

- The cutting inserts with replaceable cutting plates

## The cutting inserts with replaceable cutting plates

The cutting inserts with replaceable cutting plates are well-suited for the cutting of materials with a tensile strength of 1,200N/mm<sup>2</sup> (corded wire, screws, etc.). One advantage is the possibility to replace the cutting plates when they are worn out (the holder is reusable), and part I45C00S7 even allows the operator to turn the cutting plate, which extends the plier usage.

The turnable cutting plates are made from steel and feature a high durability.

All of the listed cutting-inserts are intended for their use with our size 45 pliers, model no's: P0452X-C00, P0452Z-C00 und P0453-C00.

Type	Part No.	Price EUR / each
<b>I45C00S4</b>	<b>6951399</b>	*
<b>I45C45S4</b>	<b>6950518</b>	*
<b>I45C90S4</b>	<b>6951369</b>	*
<b>I45C00S7</b>	<b>6950594</b>	*

\* Price will be set upon test results of a specific inquiry

## Advantages:

- Extended longevity
- Multi-purpose application



## 1) I45C00S4 (cutting angle 0°)

Type	Part No.
<b>I45C00S4</b>	<b>6951399</b>
Cutting plate (2x)	6951289
Socket wrench Torx T20	6080289

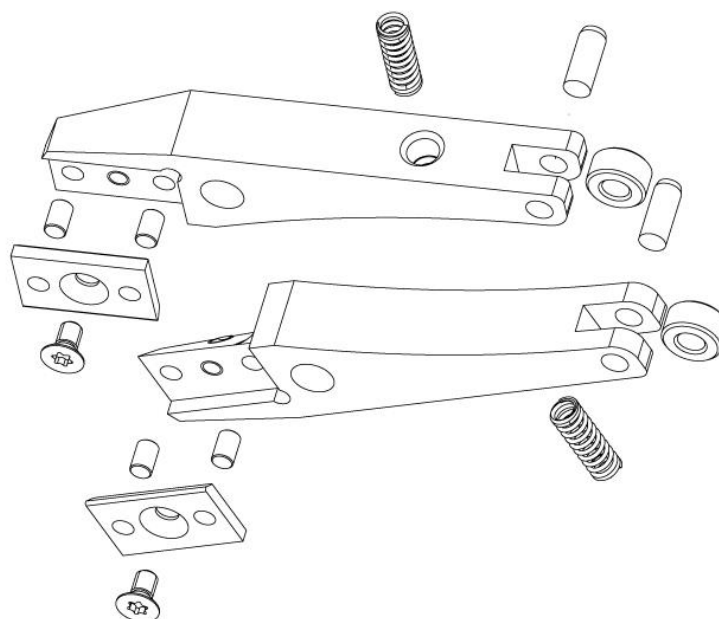
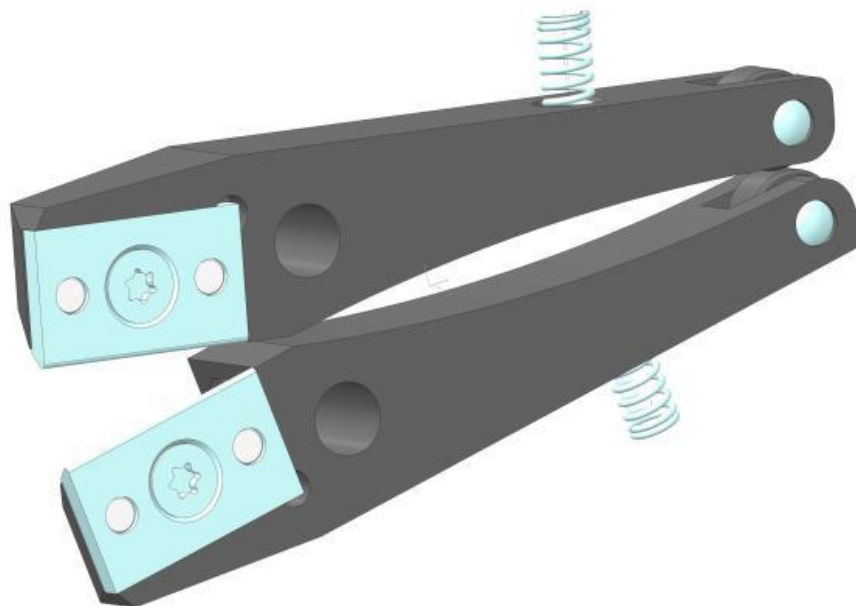

## 2) I45C45S4 (cutting angle 45°)

Type	Part No.
<b>I45C45S4</b>	<b>6950518</b>
Cutting plate (2x)	6951289
Socket wrench Torx T20	6080289

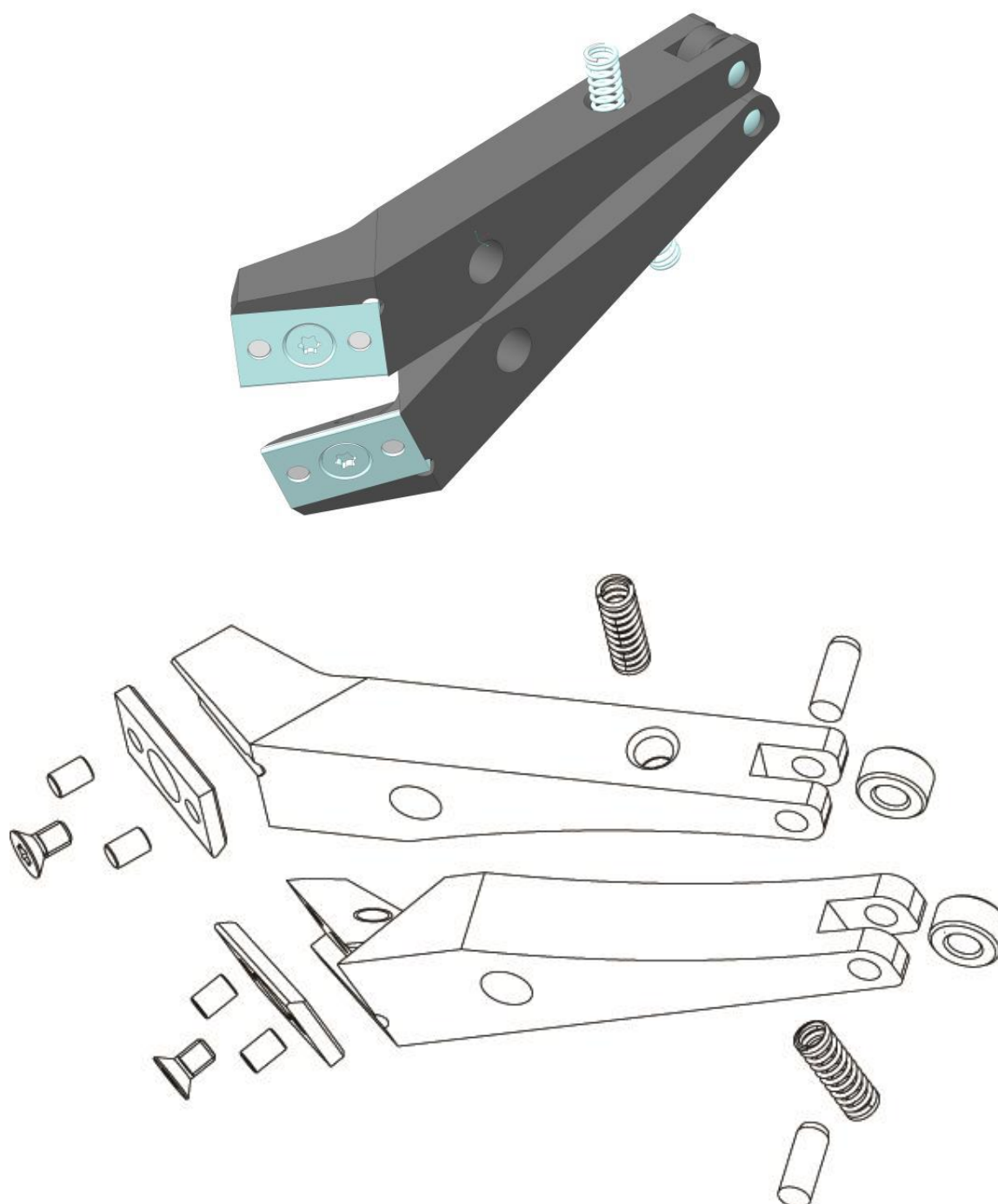

### 3) I45C90S4 (cutting angle 90°)

Type	Part No.
<b>I45C90S4</b>	<b>6951369</b>
Cutting plate (2x)	6951368
Socket wrench Torx T20	6080289

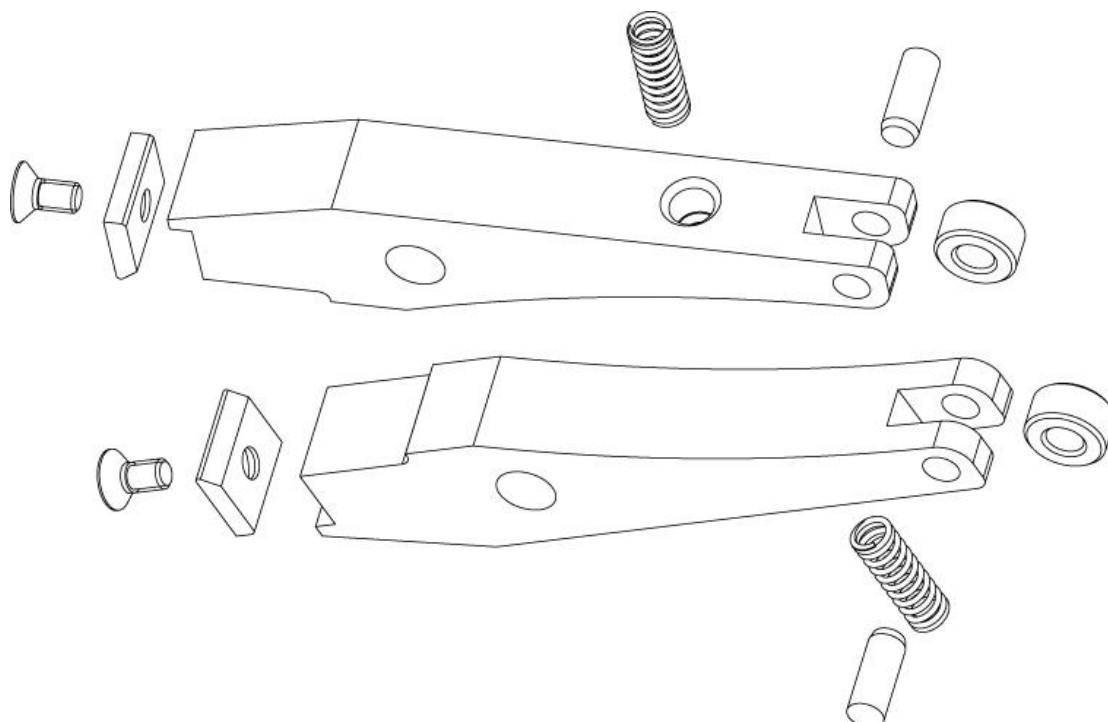
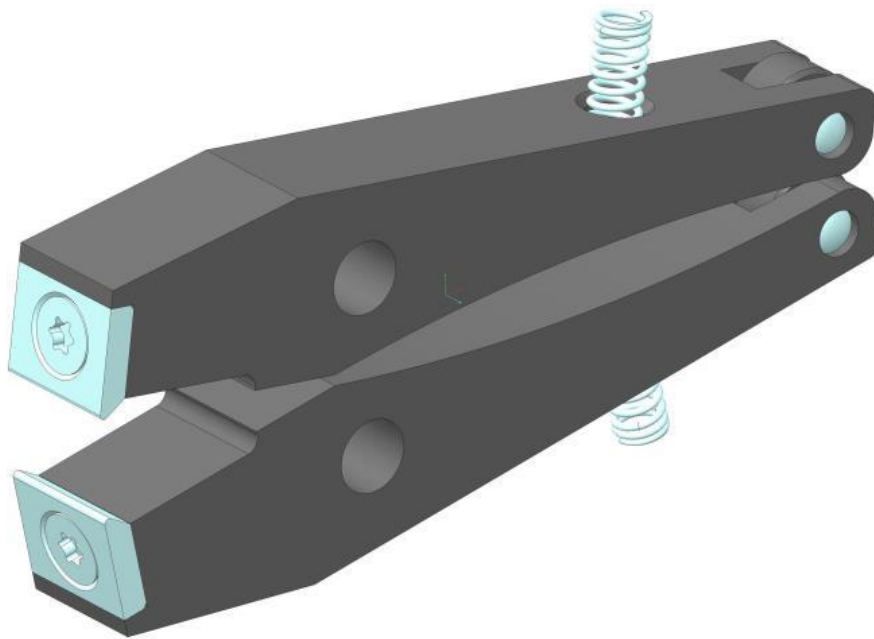

#### 4) I45C00S7 (cutting angle 0°, tripple cutting edge)

Type	Part No.
<b>I45C00S7</b>	<b>6950594</b>
Cutting plate (2x)	6950596
Allen key 2,5	800445

