

Dear DEPRAG-INDUSTRIAL Associate,
we take the opportunity to inform you about new and improved products that were either added to our product line or where we made improvements. Detailed technical information and pictures, as well as a catalog in PDF-format can be found on our website www.deprag.cz.

Program expansion DEPRAG INDUSTRIAL: Straight Grinder – Model GS 812-150BXE

Straight Grinder Model GS 812-150BXE

We are pleased to inform you that we are introducing our new Straight Grinder Model No. GS 812-150BXE for flex-grinding disks (type 27). The grinder is designed to perform best on heavy duty, industrial applications – even when used in 24/7 operations.

Model	Part Number
GS 812-150BXE	6061279A

Applications:

- machine building
- foundries
- grinding room
- automotive industry
- production of containers, railway carriages, construction etc.



Our air straight grinder is used with flex grinding disks, wherever heavy-duty fabrication is required on steel and castings or when deburring welding-, casting-, and ridge-seams. It has never been easier to perform smooth or coarse grinding of steel & cast iron in foundries, or when polishing welding seams or when fabricating casted parts.

Our straight grinder can also be used with steel brushes for the removal of rust or when descaling rolled steel and forgings.

Advantages:

- optimal power-to-weight ratio, high power
- robust, ergonomic
- extremely durable
- easy to operate
- with autobalancer for reduced vibrations



Specifications:

Straight Grinders for Flex Grinding Disk (Type 27)	Model Part No.	GS 812-150BXE 6061279A	
Speed (no load)	min ⁻¹ (rpm)	12 000	
Max. power output	kW (hp)	1,5	(3.31)
Air consumption (loaded)	m ³ /min (cfm)	1,7	(60.0)
Air consumption (no load)	m ³ /min (cfm)	0,7	(24.7)
I.D. of air inlet hose	mm (in)	13	(.51)
Grinding disk – Ø outside	mm (in)	125	(5")
Grinding disk – width	mm (in)	2,5÷8	(.10-.31)
Max. allowable speed	m/s (ft/s)	80	(3.15)
Air connection		thread 3/8"female	
Vibration a _{hd}	m/s ²	0,8 (K=0,26)	
Sound pressure level A, L _{pA}	dB(A)	83,0 (K=3)	
Sound power level A, L _{wa}	dB(A)	94,0 (K=3)	
Weight	Kg (lbs)	2,7	(5.95)

Specifications at 90 psi (6,3 bar)

Standard Equipment:

Allen key 2 mm, 5 mm, 6 mm,
Part No. 800443, 800448, 800449

T Wrench, Part No. 828832

Hose nozzle, Part No. 6013772



Optional Accessories:

Swivel connector, Part No. 816376

The swivel is an ingenious multi-directional connector. Connect your tool and the hose will stay in the ideal position however much you and the tool move around. The swivel connector bends and rotates 360° in all directions while the hose stays straight. It takes the effort out of working in those cramped spaces, the hose feels almost weightless and it reduces hose wear.



Hose nozzle, turn-able G3/8", SW10,
Part No. 6022433



Hose nozzle G3/8", SW10, Part No. 6072227
+ Ring, Part No. 6070103



Specifications – dimensional-sketch (mm)

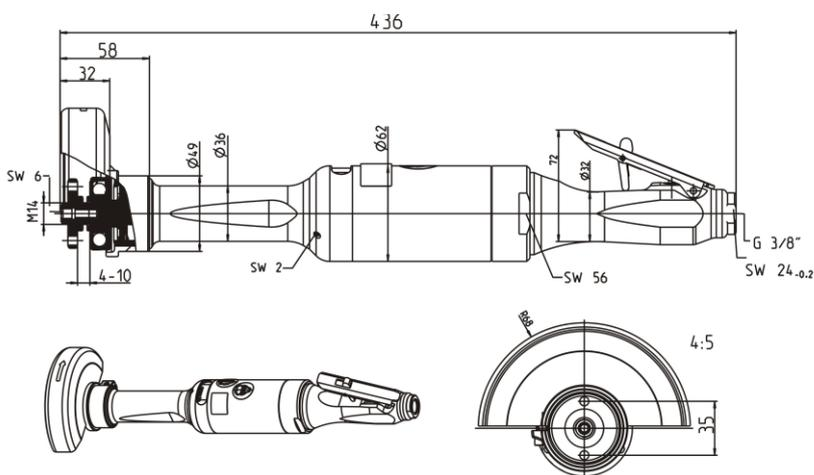

GS 812-150BXE

The grinder will be added to standard products of the DEPRAG INDUSTRIAL brand, official sale will be launched on June 6th, 2016.