



Schraubtechnik

Automation

Druckluftmotoren

Druckluftwerkzeuge



Hartmetallfräser



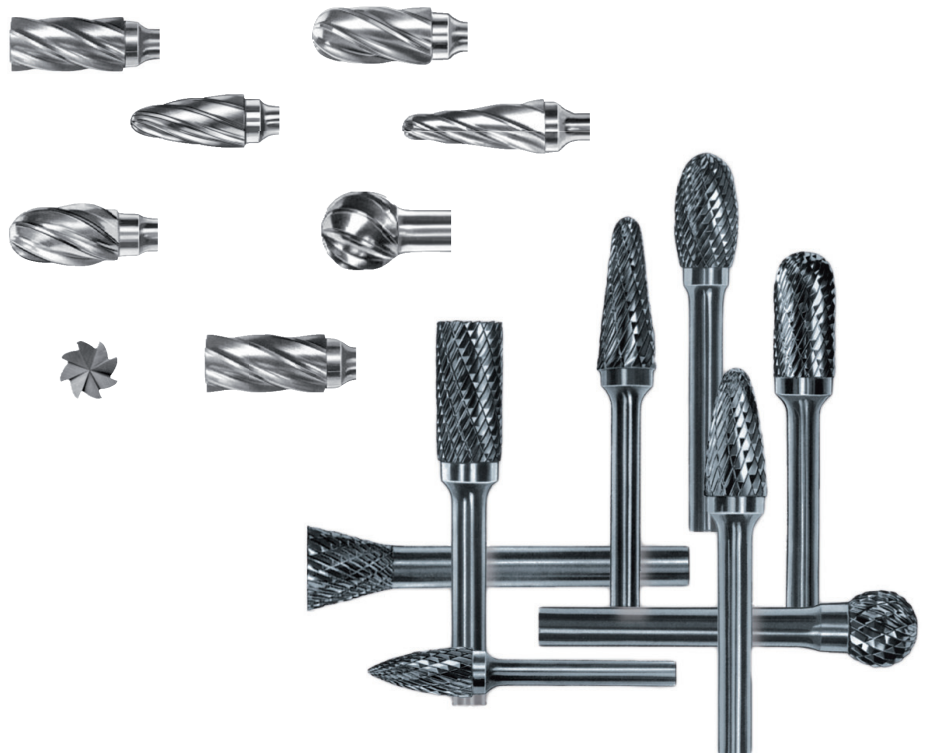





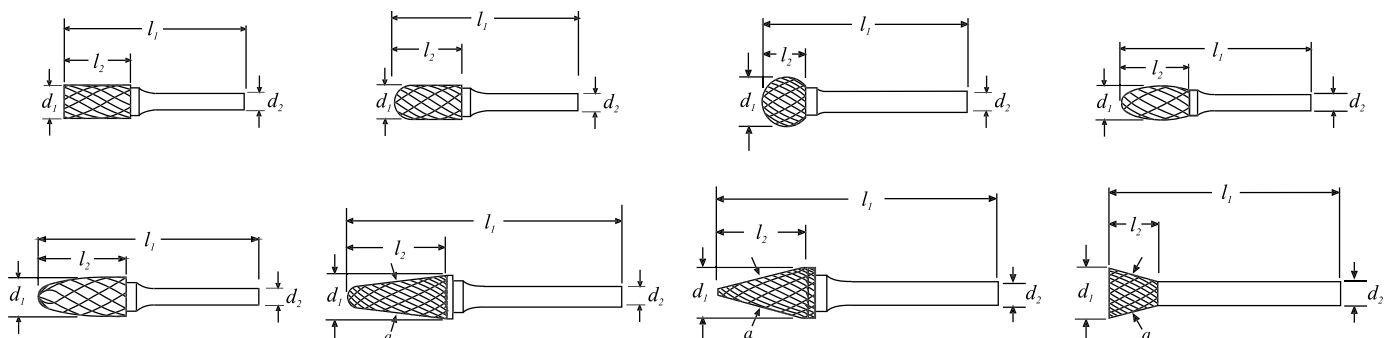

(für verschiedenste Applikationen - Walzenform, Kugelform, ovale Form, Baumform mit rundem Ende, mit spitzem Ende, Flammenform, Kegelform usw.)



HARTMETALLFRÄSER - FÜR STAHL

Ausführung







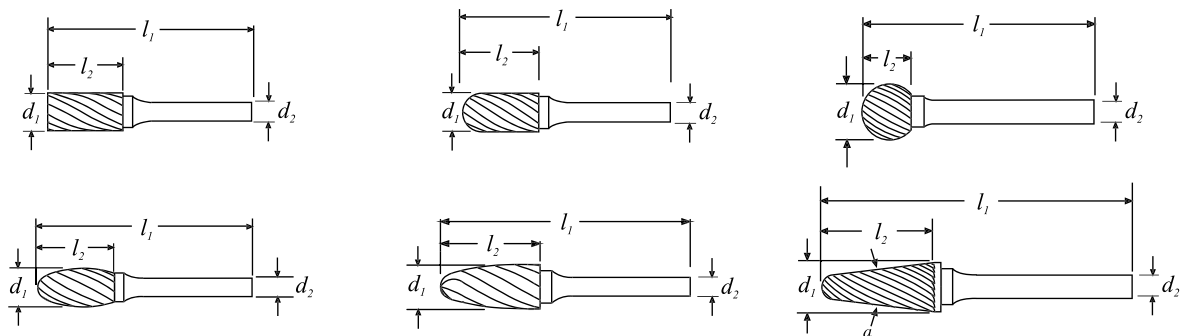

Typ	Bestell-Nr.	Grundmaße (mm)					
		$\varnothing d_1$	$\varnothing d_2$	l_1	l_2	a	
Walzenform ohne vordere Schneide 	SA-42M	6074551	2,5	3	38	11	-
	SA-1M	6074576	6	6	50	16	-
	SA-3M	6074577	9,5	6	63	19	-
	SA-5M	6074552	12,7	6	69	25	-
Walzenform mit vorderer Schneide 	SB-43M	6074553	3	3	38	14	-
	SB-1M	6074578	6	6	50	16	-
	SB-3M	6074579	9,5	6	63	19	-
	SB-5M	6074565	12,7	6	69	25	-
Walzenform mit rundem Ende 	SC-42M	6074556	3	3	38	14	-
	SC-1M	6074555	6	6	50	16	-
	SC-3M	6074557	9,5	6	63	19	-
	SC-5M	6074558	12,7	6	69	25	-
Kugelform 	SD-42M	6074559	3	3	38	2,8	-
	SD-1M	6074580	6	6	50	5	-
	SD-3M	6074581	9,5	6	52	8	-
	SD-5M	6074560	12,7	6	55	11	-
Ovale Form 	SE-41M	6074561	3	3	38	5,5	-
	SE-1M	6074582	6	6	50	9,5	-
	SE-3M	6074583	9,5	6	60	16	-
	SE-5M	6074562	12,7	6	66	22	-
Baumform mit rundem Ende 	SF-42M	6074563	3	3	38	12,7	-
	SF-1M	6074584	6	6	50	16	-
	SF-3M	6074564	9,5	6	63	19	-
	SF-5M	6074565	12,7	6	69	25	-
Baumform mit spitzem Ende 	SG-43M	6074566	3	3	38	6	-
	SG-1M	6074585	6	6	50	16	-
	SG-3M	6074567	9,5	6	63	19	-
	SG-5M	6074586	12,7	6	69	25	-
Flammenform 	SH-41M	6074568	3	3	38	6,3	-
	SH-53M	6074587	5	3	38	9,5	-
	SH-2M	6074588	8	6	63	19	-
	SH-5M	6074569	12,7	6	76	32	-
Kegelform mit rundem Ende 	SL-42M	6074570	3	3	38	12,7	8°
	SL-1M	6074589	6	6	50	16	14°
	SL-3M	6074590	9,5	6	74	27	14°
	SL-4M	6074571	12,7	6	76	28	14°
Kegelform 	SM-42M	6074572	3	3	38	11	14°
	SM-2M	6074591	6	6	50	19	14°
	SM-4M	6074572	9,5	6	63	16	28°
	SM-5M	6074573	12,7	6	69	22	28°
Kegelform umgekehrt 	SN-42M	6074574	3	3	38	4	10°
	SN-1M	6074593	6	6	50	8	10°
	SN-2M	6074594	9,5	6	53	9,5	13°
	SN-4M	6074575	12,7	6	57	12,7	28°

HARTMETALLFRÄSER - FÜR ALUMINIUM

Ausführung



Typ	Bestell-Nr.	Grundmaße (mm)					
		$\varnothing d_1$	$\varnothing d_2$	l_1	l_2	a	
Walzenform 	SA-1MNF	6076470	6	6	50	19	-
	SA-3MNF	6076471	9,5	6	63	19	-
	SA-5MNF	6076472	12,7	6	69	25	-
	SA-6MNF	6076473	16	6	69	25	-
	SA-7MNF	6076474	19	6	69	25	-
Walzenform mit vorderer Schneide 	SB-1MNF	6076475	6	6	50	19	-
	SB-3MNF	6076476	9,5	6	63	19	-
	SB-5MNF	6076477	12,7	6	69	25	-
	SB-6MNF	6076478	16	6	69	25	-
	SB-7MNF	6076479	19	6	69	25	-
Walzenform mit rundem Ende 	SC-1MNF	6076480	6	6	50	19	-
	SC-3MNF	6076481	9,5	6	63	19	-
	SC-5MNF	6076482	12,7	6	69	25	-
	SC-7MNF	6076483	19	6	69	25	-
Kugelform 	SD-1MNF	6076484	6	6	50	5	-
	SD-3MNF	6076485	9,5	6	52	8	-
	SD-5MNF	6076486	12,7	6	55	11	-
	SD-6MNF	6076487	16	6	58	14	-
	SD-7MNF	6076488	19	6	62	16	-
Ovale Form 	SE-3MNF	6076489	9,5	6	60	16	-
	SE-5MNF	6076490	12,7	6	66	22	-
	SE-6MNF	6076491	16	6	69	25	-
	SE-7MNF	6076492	19	6	69	25	-
Baumform mit rundem Ende 	SF-1MNF	6076493	6	6	50	19	-
	SF-3MNF	6076494	9,5	6	63	19	-
	SF-5MNF	6076495	12,7	6	69	25	-
	SF-6MNF	6076496	16	6	69	25	-
	SF-14MNF	6076497	19	6	76	32	-
Kegelform mit rundem Ende 	SL-3MNF	6076498	9,5	6	74	27	14°
	SL-4MNF	6076499	12,7	6	76	28	14°
	SL-5MNF	6076500	16	6	77	30	14°
	SL-7MNF	6076501	19	6	85	38	14°

Dle požadavku lze zajistit dodávky dalších typů tvrdokovových fréz.

DEPRAG
DEPRAG CZ a.s., Lázně Bělohrad



DEPRAG CZ a.s., T. G. Masaryka 113, 507 81 Lázně Bělohrad - Tschechische Republik
Tel.: +420-493 771 511, Fax: +420-493 771 623, E-mail: sales@deprag.cz, Internet: www.deprag.cz